



LF SERIES

Folder ~ Crossfolder ~ Draper ~ Stacker



Working Width Available In: 120" and 130"

Application

- The LF Series is a large piece folder/crossfolder with up to 3 optional large piece stackers for post-folding automatic sortation. In addition, it offers optional small piece folding and draping capability.

LEONARD AUTOMATICS, INC.

"our reputation is stainless"®

The LF Series Folder/Crossfolder

Incredible versatility for any commercial, hospitality or healthcare linen supplier.

- High speed folding and cross-folding with optional small piece folding and draping capability. The LF Series comes in 120" and 130"



Versatility

- The LF Series has up to 2 lanes for large pieces and 5 lanes for small pieces. This provides the utmost in versatility for any commercial, hospitality or healthcare linen supplier.

Sorting on the Fly

- The LF Series has the option of adding up to 3 large piece stackers for post-folding automatic sortation.

Durable and Dependable Design

- Engineered by Leonard Automatics and built in our North American factory to the same quality standards as all Leonard equipment.



PLC Controlled

- All Leonard Folders are equipped with the easy-to-use Siemens PLC interface.

PLC Standard Features

- The ability to configure all folding and stacking functions right on the easy-to-use HMI.
- Operating and diagnostic testing to include air blast start-up test, photo eye start-up test and automatic jam location detection.
- Automated troubleshooting, alarm logs, PM schedule, and runtime history.



PLC Optional Features

- Additional languages available upon request.
- Ability to accommodate stain/tear reject from any spreader/feeder manufacturer.



TECHNICAL SPECIFICATIONS

Connections

Electrical	Air	Dimensions	Weight
230 – 460 / 3 / 60 FLA 15.5 / FLA 7.75	Min. 80 psi Max. 100 psi	140 x 176 x 70	7000 lb

Capabilities

Mode	Primary Folds	Cross Folds
Small Piece Five Lane	0 – 1 – 2	Bar Drape
Large Piece Sin- gle Lane	2 – 3	3
Large Piece Two Lanes	2 – 3	Manual

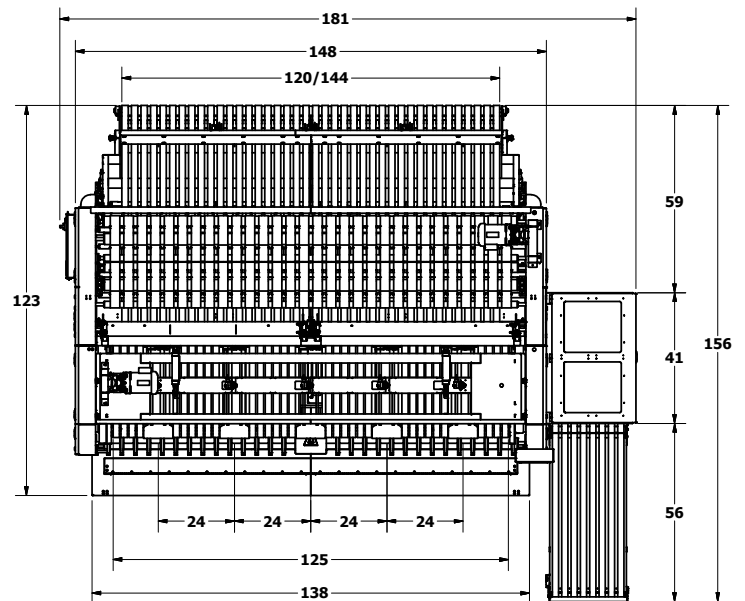
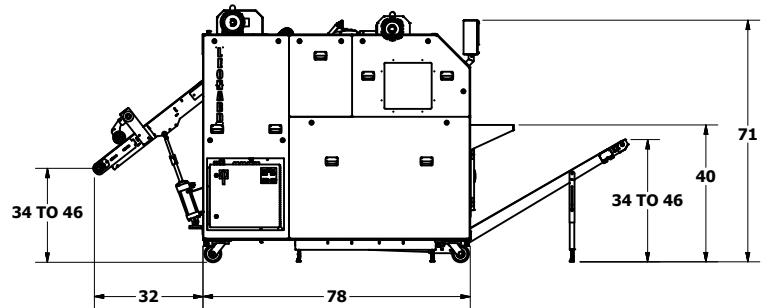

Speed

- The LF Series has a conveyor speed of up to 150 feet per minute.

Small to Large Capability

- Process a wide range of linens from pillow cases to California king sheets to napkins and table cloths it will also do table rounds.

Additional Options

- Stain and tear reject capability with a button bar installed at the front of the ironer.
- The LF series can be outfitted with up to 3 large piece stackers for automatic post-folding sortation.
- Available in 120" - 5 lane, 130" - 5 lane

*Please consult layout drawings for detailed dimensions including conveyor, control panels and utility connections.
Specifications subject to change without notice.
Manufactured in the U.S.A.
Updated: 06/05/2019



5894 Balsom Ridge Rd. / PO Box 501 Denver, NC 28037
ph: 704-483-9316 / fx: 704-483-4538
sales@leonardautomatics.com - <http://leonardautomatics.com>